

SNG High Performances Green Microchip Series

Key features

- ▶ Repetition rate up to 40kHz
- ▶ Ultrashort pulses down to 650ps
- ▶ Multi-kW peak power
- ▶ Excellent beam quality – TEM₀₀, $M^2 < 1.1$
- ▶ Efficient, air-cooled
- ▶ Sealed package, extremely long life



For generating high peak power Green pulses of a few hundred picoseconds, microchip lasers are economical, compact, and reliable. 532nm pulses are subsequently produced by harmonic conversion from the IR systems, the same sealed package being used for either wavelength. The SNG II series are designed for high average power, delivering multi-kW peak power at repetition rates up to 40kHz.

Applications

- ▶ Material processing
 - Cost effective marking solutions
 - Graphitization
- ▶ Instrumentation
 - Ranging
 - Differential absorption LIDAR
 - Super-continuum generation
 - Distributed temperature sensing
 - Raman spectroscopy
- ▶ Biophotonics
 - Nanosurgery
 - Protein cross-linking

For your application, find your pulsed laser solution

teem photonics™

Technical specifications:

	SNG-03E-xxx	SNG-20F-xxx	SNG-40F-xxx⁽⁶⁾
Wavelength	532nm	532nm	532nm
Repetition Rate	>5kHz	>19kHz	>35kHz
Constant Pulse width range (FWHM) ⁽¹⁾	<0.75ns	<0.75ns	<0.75ns
Output power⁽²⁾	>15mW	>48mW	>52mW
Output energy	>3μJ	>2.5μJ	>1.5μJ
Peak Power	>4kW	>3kW	>2kW
Short term (1min) power stability ⁽³⁾	<±1%	<±1%	<±1%
Long term (6 hrs) power stability⁽³⁾	<±3%	<±3%	<±3%
Beam profile	Gaussian TEM00	Gaussian TEM00	Gaussian TEM00
Full angle divergence Horizontal@1/e² Vertical@1/e²	10±2 mrad 9±2 mrad	10±2 mrad 9±2 mrad	10±2 mrad 9±2 mrad
M²⁽⁴⁾	<1.3	<1.3	<1.3
Beam ellipticity⁽⁵⁾	<1.3	<1.3	<1.3
Polarization	Linear PER>20dB	Linear PER>20dB	Linear PER>20dB
Package dimensions	115x29x35mm	145x42x35mm	145x42x35mm
Package weight	250g	300g	300g
Options (table p3)	CDRH	CDRH, S	CDRH, S

Notes

(1)	Measured with 1GHz photodiode and 1GHz/10GS/s oscilloscope.
(2)	Measurement performed with an OPHIR thermal power sensor (OPHIR 3A-FS-SH)
(3)	For temperature variation < ± 3°C and < 3°C/hour, stability is measured with calorimeter - detector band [DC, 2Hz]
(4)	Mean average value $M = \sqrt{XY}$, X and Y being respectively the major and minor axis of the ellipse
(5)	Beam ellipticity is calculated as the ratio of the main axis far field divergence
(6)	Contact factory for availability

For your application, find your pulsed laser solution

teem photonics™

Complementary information & options:

Environment Parameters

Operating Temperature Range	0-50°C
Maximum Laser Head Baseplate Temperature	<50°C
Maximum Power Consumption	<40W
Laser Head Thermal Dissipation	<15W
Storage Temperature	0-50°C
Shock of 11ms according to IEC 68-2-27, non operating	25g
Vibration 5Hz to 500Hz sinusoidal according to IEC 68-2-6	2g

Certification

Laser classification according to IEC 60825-1:2007	3B
CDRH	Yes, if used with a -DR1 controller
ROHs	Yes

Options

CDRH	With a mechanical shutter
Synchronization output (S)	TTL compatible output signal for synchronization/monitoring

Available Controller Types

Model	Type	Input Power	CDRH
MLC-03A-DR1	Desktop	100-240 V AC	Yes
MLC-03A-MR1	Module	12 V DC	No
MLC-03A-BR1	Board	12 V DC	No

For your application, find your pulsed laser solution

teem photonics™

CDRH Laser Head Mechanical Drawings : SNG-20F, SNG-40F

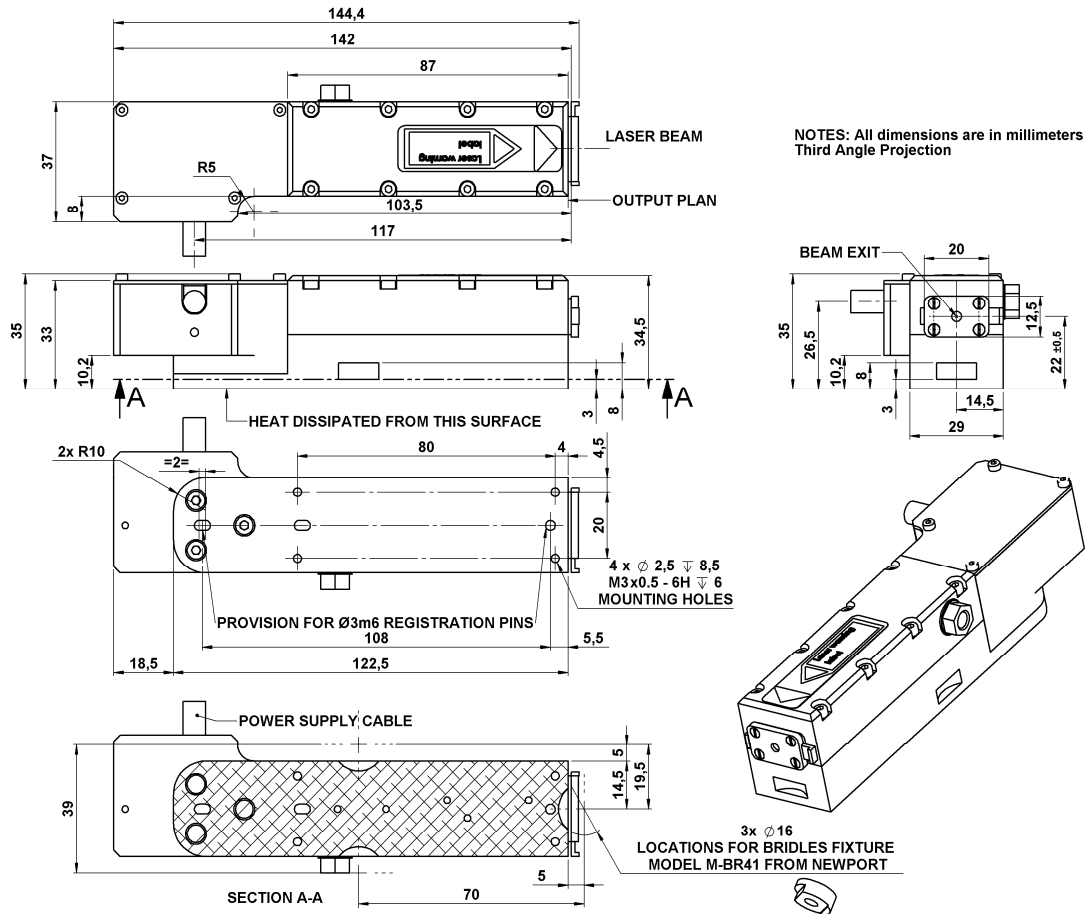

CDRH Laser Head Mechanical Drawings : SNG-03E

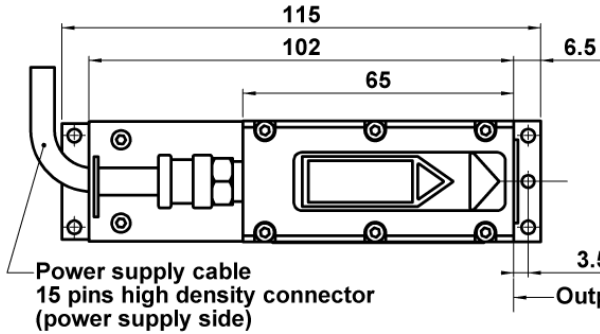

NOTES: All dimensions are in millimeters
Third angle projection

3.5 (Registration pin)
Output plan

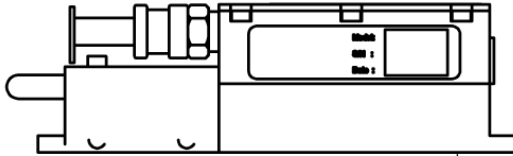
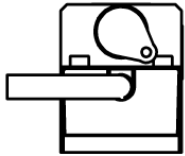

Heat dissipated from this surface

